

# Manual for Owners and Skippers

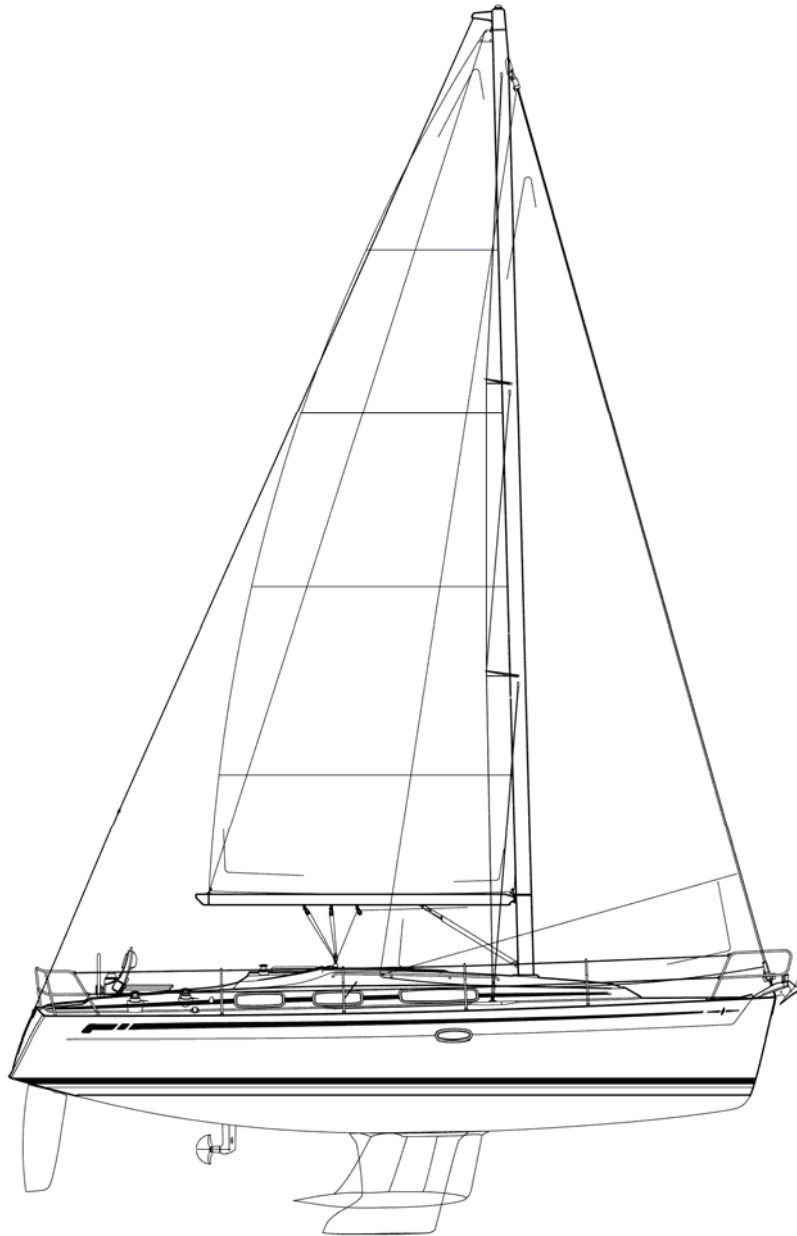

Sailing yacht „Bavaria 38 Cruiser“



Bavaria Yachtbau GmbH • Bavariastr. 1 • D – 97232 Giebelstadt  
Tel.: +49 (0) 9334 942 – 0; Fax: +49 (0) 9334 942 – 116  
e-mail: [info@bavaria-yachtbau.com](mailto:info@bavaria-yachtbau.com)

**INDEX**

Introduction .....	4
Category of design .....	5
Certification .....	5
Identification .....	5
Builder's plate .....	5
Explanations .....	5
Warnings .....	6
Declaration of Conformity .....	7
1. Description of the yacht .....	12
1.1 Main particulars .....	12
1.1.1 Principal dimensions .....	12
1.1.2 Displacement and weights .....	12
1.1.3 Motorization .....	12
1.1.4 Electrical installation .....	12
1.1.5. Tank capacities .....	12
1.1.6. Fixing points for cranes, resting-points for slipping and transport .....	12
1.2 General arrangement .....	13
1.2.1 Rigging plan .....	13
1.2.2 Deck arrangement .....	14
1.3 Drive systems .....	17
1.3.1 Sails .....	17
1.3.2 Rigging .....	17
1.3.3 Motorizing, engine room, gear, and propeller .....	17
2. Installations and circuits .....	19
2.1 Tanks and piping - water .....	19
2.1.1 Fresh water, drinking water –cold .....	19
2.1.2 Sea-water circulation .....	19
2.1.3 WC –installation: see enclosed directions for use .....	20
2.2 Tanks and piping - fuel .....	21
2.3 Steering gear .....	21
2.3.1 Description of the system .....	21
2.3.2 Rudder blade and rudder bearings .....	21
2.4. Bilge pumps, bilge pipes .....	23
2.4.1 Description of the pumping arrangement .....	23
2.5 The electric installation .....	24
2.5.1 The AC-installation 220 Volt .....	24
2.5.2 The DC–board net 12 Volt .....	24
2.5.3 Operating the installation and specific features .....	24
2.5.4 Important warnings on the DC-installation (12 Volt) .....	25

2.5.5 Important warnings on the AC-installation (230 Volt/115 Volt) .....	25
2.5.6 Distribution of electric devices:.....	26
2.5.7 Wiring plans .....	28
2.5.8 Distribution plans .....	28
2.5.9 AC-Distribution.....	28
2.6 L.P.G. installation .....	28
2.6.1 The components .....	28
2.6.2 Operation .....	29
2.7 Fire protection.....	29
2.8 Anchor-, towing- and warping facilities .....	31
2.9 Engine cooling system .....	31
2.13 Generator (Option für 44vision, 50vision, 50 Cruiser, 51 Cruiser) .....	33
3. Environmental protection .....	34
3.1 Fuel and oil .....	34
3.2 Waste.....	34
3.3 Sound .....	34
3.4 Swell .....	34
3.5 Exhaust gas .....	34
3.6 Antifouling coatings.....	34
3.7 Varnish removers .....	34
4. Maintenance.....	35
4.1 Maintenance, cleaning .....	35
4.2 Wearing- and spare parts.....	36
4.3 Repair work.....	36
4.4 Winter storage.....	36
5. Final remarks and notes .....	38
6. List of manuals supplied.....	39

## Introduction

This manual will help you to handle your yacht safely and with pleasure. Apart from information about the yacht itself and installed or additionally supplied fittings the manual also contains information on operation and maintenance. Please familiarise yourself with everything before you go on your first voyage.

If this is your first yacht or if you are not really familiar with the special characteristics of a motor yacht please make sure you get proper training before you put it into operation. Do not hesitate to contact the dealer or our shipyard for information about further training possibilities.

As the scope of supply depends on the order, the equipment of your yacht can deviate with some descriptions and illustrations. In order to be able to adapt our yachts to the constantly progressing technical standard, we must reserve ourselves changes in form, equipment and technology. For these reasons no requirements can be derived from all data, illustrations and descriptions in this manual.

**PLEASE KEEP THIS MANUAL IN A SAFE PLACE  
AND HAND IT OVER TO THE NEW OWNER IF YOU SELL THE YACHT.**

**BAVARIA** would like to welcome you to the circle of **BAVARIA** owners and would like to thank you for placing your confidence in our products by acquiring this yacht.

Your contract partner and the management and staff of Bavaria Yachtbau GmbH hope you will enjoy your new yacht.

*Bon voyage, fair winds and fine weather.*

BAVARIA Yachtbau GmbH  
Management



K. Hammen

## Category of design

Following the European Recreational Craft Directive each boat has to be classified according to a category of design.

**All sailing yachts of BAVARIA belong to the category of design A.**

Designed for extended voyages where conditions may exceed wind force 8 (Beaufort scale) and significant wave heights of 4 m and above but excluding abnormal conditions, and vessels largely self-sufficient.

## Certification

Actually the EC Directive intends for yachts of this size the certification module **B**.

**IMCI (International Marine Certification Institute) from Bruxelles** was put into charge as a notified body (see: Declaration of Conformity).

## Identification

The hull identification was formed into the transom on starboard side. This is a unique sequence of digits and letters.

## Builder's plate

The builder's plate on the front wall of the cockpit is a demand of the Directive because certain information are required which will be explained in the following.

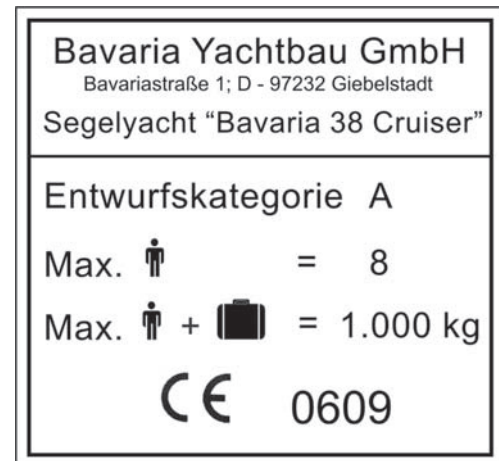

## Explanations

- **Category of design A:** Ocean

- **Max. 8:**

Maximum number of persons recommended by the manufacturer if the yacht is situated in the sea area corresponding to the category of design. The number of crew can be increased under consideration of the maximum additional loading capacity if the yacht is on a voyage in non-ocean areas.

- **Max. 1.000 kg:**

Maximum additional loading including 8 persons, stores, provisions and personal equipment (excluding tank capacities).

- **CE 0609:**

CE marking which indicates the conformity of the yacht with all provisions of the Directive. The sequence of digits is the code number of the certifying body, in this case the **IMCI (International Marine Certification Institute)** (see: Declaration of Conformity).

## Warnings

Many chapters of this manual will support a trouble free operation, maintenance or draw your attention to signs of dangers. To find them more easily they are especially marked (in boxes or in bold). We advise you to study them carefully although the experienced skipper might be quite familiar with many of them.

The following chapters contain such warnings/notes or other important information for operating the yacht.



**Always consider the maritime duty to exercise diligence!**



**Danger**

Means, that an extreme real hazard which will lead to the death or too irreparable injuries with great probability exists if no adequate precautions are found.



**Warning**

Means, that a hazard which can lead to injuries or death exists if no adequate precautions are found.



**Caution**

Means that a memory of safety measures or the attention judges on handling, which can be unsure or lead to personal injuries or to harm of the vessel or from components.

## Security advice



**Attention!**

From wind force 6 the hatch in the cab entrance is to be closed.



**Attention!**

Starting from wind force 6 the cab windows in the cockpit are to be closed.



**Attention!**

Make yourself and your crew familiar with the bath platform. It makes the re-entrance possible!

Maximum capacity 2 persons (150kg)

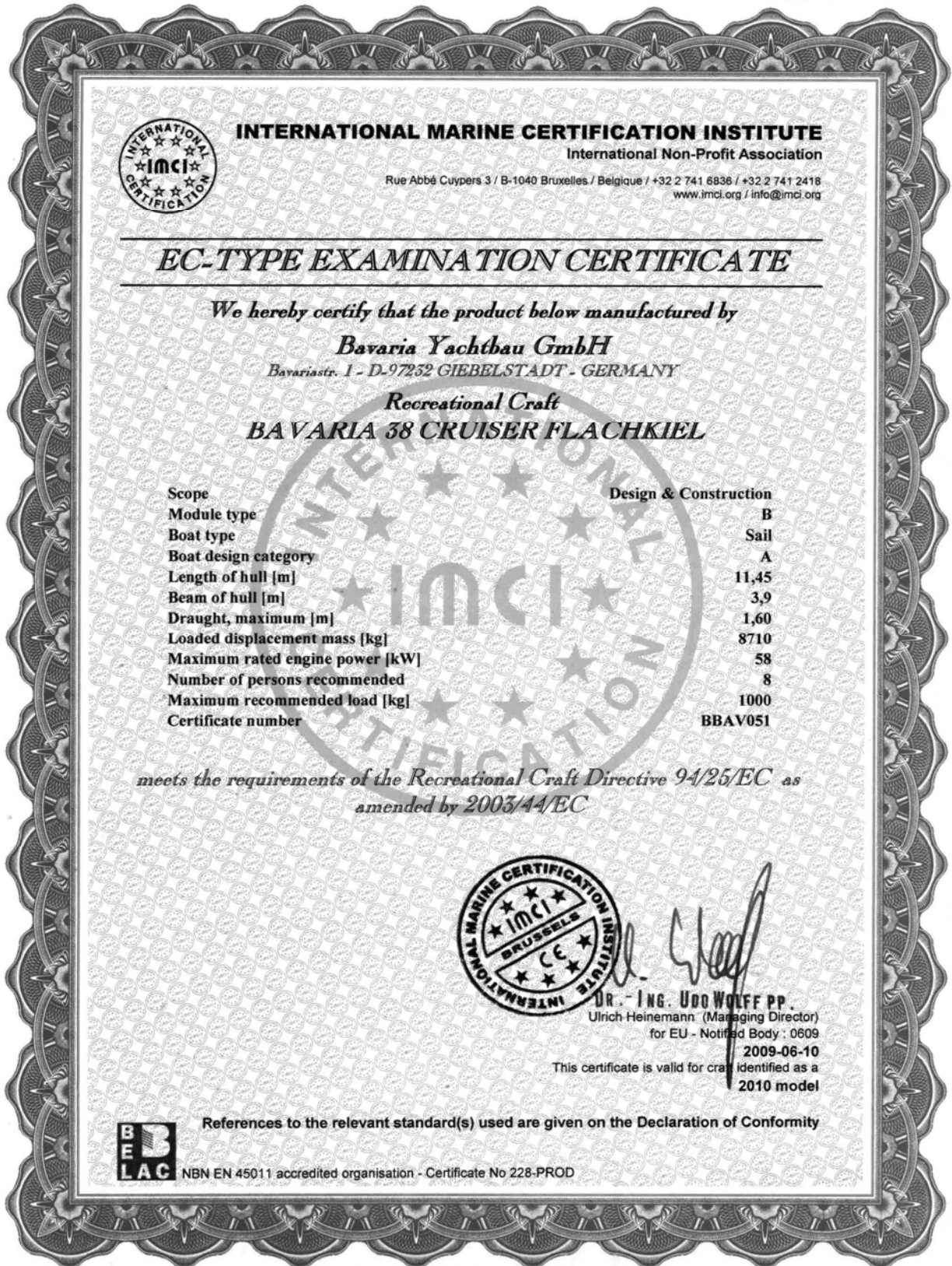

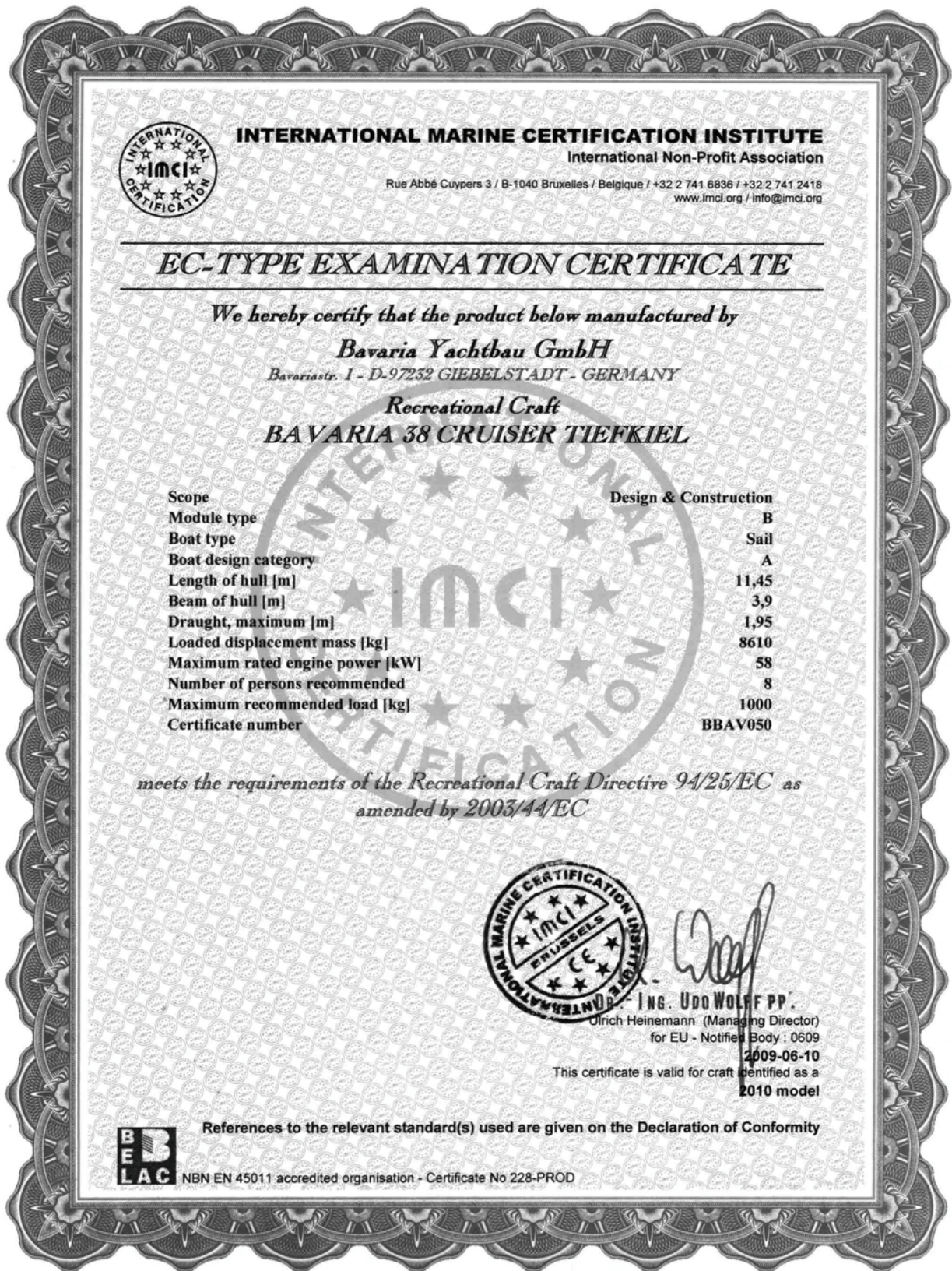

# VOLVO PENTA

Declaration of Conformity for Recreational Craft Propulsion Engines with the exhaust emission requirements of Directive 94/25/EC as amended by 2003/44/EC

## D1-13, D1-20, D1-30, D2-40

**Engine manufacturer:**

AB Volvo Penta  
Gropegårdsgatan  
405 08 Göteborg  
Sweden

**Body for exhaust emission assessment:**

NKIP  
Nipkowweg 9  
Postbus 65  
8500AB Joure  
Netherlands  
**ID Number:** 0613

**Module used for exhaust emission assessment** ..... B, EC Type Examination acc to Annex VII  
**Other Community Directives applied** ..... EMC 89/336/EEC

**Description of engine(s) and essential requirements**

**Engine Type** ..... 4 stroke diesel engine

Engine model(s) covered by this declaration	EC Type certificate number
D1-13 .....	CE-RCD-540
D1-20 .....	CE-RCD-540
D1-30 .....	CE-RCD-541
D2-40 .....	CE-RCD-541

Essential requirements	Standards Used	Other normative document used
<b>Annex I.B – Exhaust Emissions</b>		
Engine identification	Volvo Penta std	Annex 1.B.1
Exhaust emission requirements	EN ISO 8178-1:1996	Annex 1.B.2
Durability	Volvo Penta std	Annex 1.B.3
Operator's manual	ISO 10240:2004	Annex 1.B.4
<b>EMC Directive</b>	EN 61000-3-2, EN 61000-3-3, CISPR 25	

This declaration of conformity is issued under the sole responsibility of the manufacturer. I declare on behalf of the engine manufacturer that the engine(s) will meet the requirements of above mentioned directives when installed in a recreational craft, in accordance with the engine manufacturer's supplied instructions and that this (these) engine(s) must not be put into service until the recreational craft into which it is (they are) to be installed has been declared in conformity with the relevant provisions of the above mentioned Directives.

**Name and function:** Sam Behrmann, Product Liability  
(identification of the person empowered to sign on behalf of the engine manufacturer or his authorised representative)

**Signature and title:**  
(or an equivalent marking)



Date and place of issue: (yr/month/day) 2005/12/16 Göteborg

PL-80/05

## 1. Description of the yacht

### 1.1 Main particulars

#### 1.1.1 Principal dimensions

Length overall	$L_{OA}$	11,72 m	Length of hull	$L_H$	11,45 m
Length on waterline	$L_W$	9,90 m	Breadth max.	B max	3,90 m
Draught – flat keel	$T_{max}$	abt. 1,55 m	Draught – deep keel	$T_{max}$	abt 1,95 m

Headroom (without antenna and similar things)	$H_D$ abt	17,50 m
Headroom (for transport)	$H_T$ abt	4,30 m

#### 1.1.2 Displacement and weights

Weight of the empty yacht -incl. safety equipment		7 000 kg
Weight of the fully equipped yacht- ready for sailing with crew	$M_{max}$	8 500 kg
	$M_{max}$	8 600 kg

#### 1.1.3 Motorization

Diesel engine:

Manufacturer Volvo Type D1-30 (21 kW), D2-40 (27 kW), D2-55 (40kW), D2-75 (53kW)

Cooling indirect (sea-/fresh-water)

Reverse-reduction gear Saildrive 130 S reduction ratio 2.19:1

Propeller: 2-bladed fixed propeller made from an aluminium alloy

#### 1.1.4 Electrical installation

##### 230V AC-installation

Shore connection	socket CEE-plug; current operated 230 V earthed socket
Battery charger	110 V/ 230 V AC / 12 V DC with 25 A max. current

##### 12 V DC-system

1 x engine battery 12 V 55 Ah	1 x bord battery (option: + 1) 12 V 140 Ah
Motor generator (alternator)	battery charger

The distribution occurs about switchboard, electric circuits with electronic protective switches and LED.

#### 1.1.5. Tank capacities

1 fresh water tank	abt 210 l	on port side below the aftcabin berth.
1 fresh water tank (opt.)	abt 150 l	in the bow.
1 fuel tank	abt 150 l	on starboard side in the locker seat.
1 holding tank	abt 80 l	
1 gas cylinder (option)	abt 3 kg cyl.	in cockpit

#### 1.1.6. Fixing points for cranes, resting-points for slipping and transport



##### Attention

The rear webbing will be placed in the area of the sail drive.

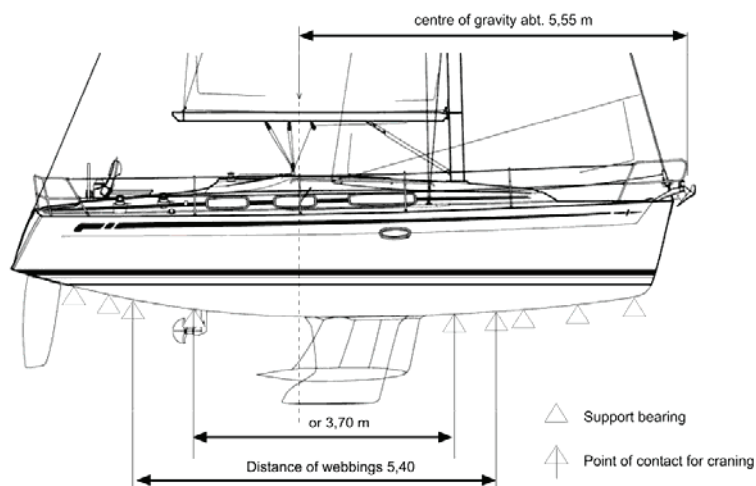

1.2 General arrangement

1.2.1 Rigging plan

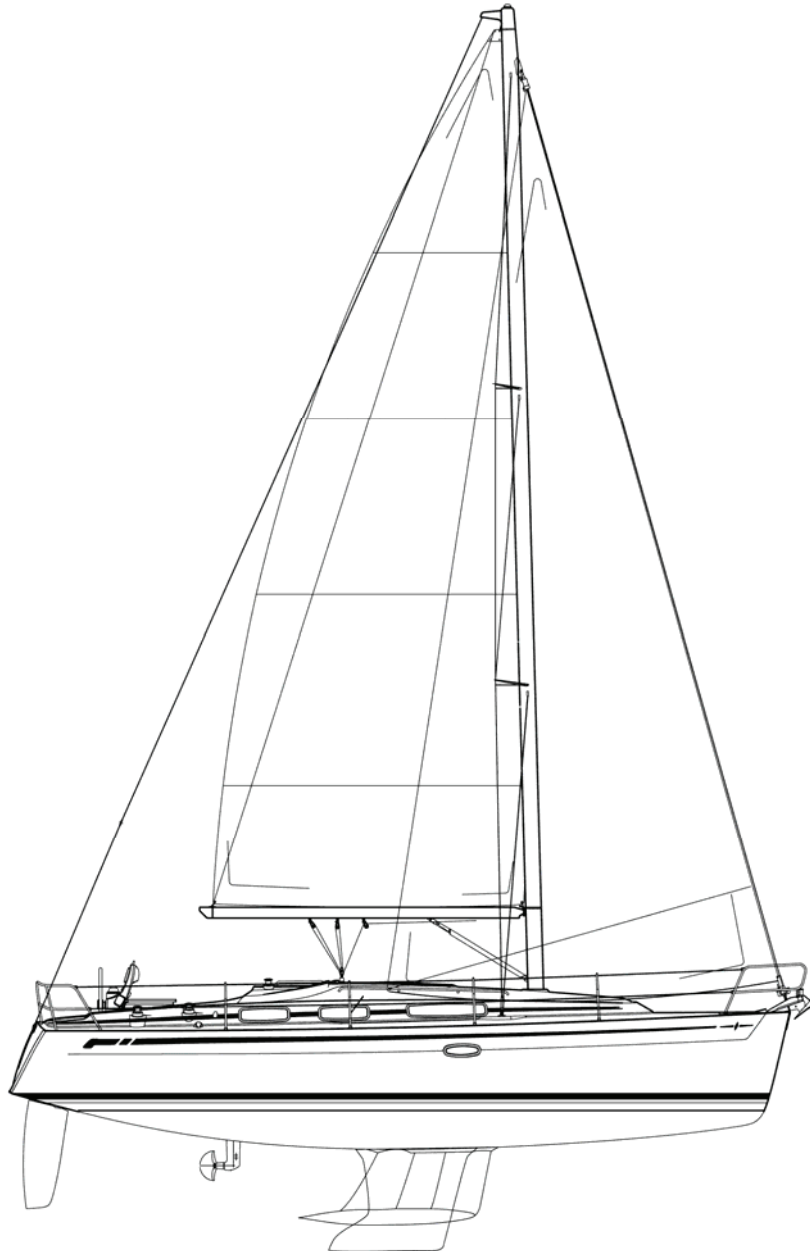

**Reference**

The valid measuring of the foresail reefing gear are on the enclosure note at the carton of the Furlex-foresail reefing gear.



**Attention!**

Do not enter front salon windows and front deck hatches. No work deck. Slip hazard!

	<b>Minimum operating condition (m<sub>MOC</sub>)</b> Standardkeel/ Deepkeel	<b>Loaded displacement condition (m<sub>LDM</sub>)</b> Standardkeel/ Deepkeel
<b>STIX</b>	<b>34,11 / 34,06</b>	<b>32,91 / 32,82</b>
<b>Angle of vanishing (degrees)</b>	<b>114,5° / 114°</b>	<b>112° / 112 °</b>

1.2.2 Deck arrangement

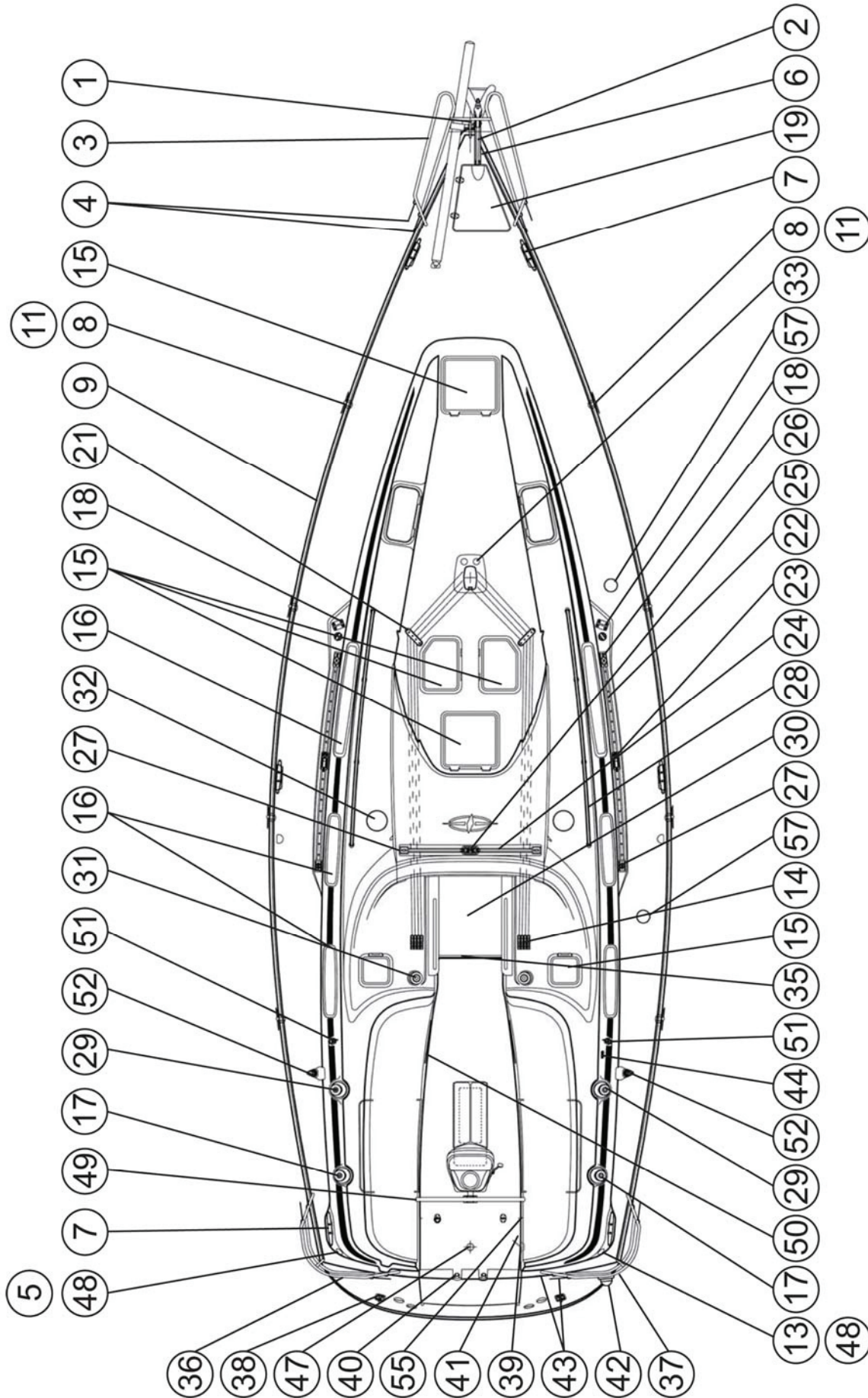

1	Bow navigational light	Zweifارbenleuchte
2	Bow fitting	Bugbeschlag
3	Bow pulpit	Bugkorb
4	Guard lines	Relingsdurchzüge
5	Water inlet	Wasser Einfüllstutzen
6	Anchor chain bail	Ankerkasten
7	Mooring cleat	Belegklampe
8	Stanchion	Relingstütze
9	Foot stop	Fussstopleiste
11	Stanchion base	Relingfuss
12	Hooking point	Deckauge
13	Fuel inlet	Diesel Einfüllstutzen
14	Op. hatch	Vorschiffsluke
15	Op. hatch	Vorschiffsluke
16	Port light	Fenster
17	Spinnaker winch	Spinnaker Winde
18	Main shrows + aft kiwers cgk	Wantenpütting
19	Electric windlass	Elektrische Ankerwinde
20	Port light	Fenster
21	Deck organizer	Umlenkblöcke
22	Genoa track	Genoaschiene
23	Genoa track car	Genoaschlitten
24	Main sheet track	Grossschotschlitten
25	Main sheet track car	Grossschotschiene
26	Front end stop (g. track)	Schienenendstück
27	Aft end stop (g. track)	Schienenendstück mit Umlenkblöcken
28	Hand hold	Handreling
29	Genoa winch	Genuawinde
30	Stopper	Stopper
31	Winch	Fallwinde
32	Ventilator	Decklüfter
33	Cable penetration	Kabeldurchführung
34	Sliding hatch	Schiebeluke
35	Companion way	Niedergangstür
36	Aft port pushpit	Heckkorb links
37	Aft starboard pushpit	Heckkorb rechts
38	Backstay chain plate	Achterstagpütting
39	Aft pushpit lifeline	Stretau mit Pelikanhaken
40	Boarding ladder	Badeleiter
41	Shower	Cockpitdusche
42	Stern light	Hecklaterne
43	Manual operated bilge pump	Handlenzpumpe
44	Shore socket 230 V	Steckdose 230 V
45	Engine ventilation inlet	Belüftungsroste
47	Tiller	Notpinne
48	Tank venting	Tankentlüftung
49	Steering wheel	Steuerrad
50	Cockpit port light	Cockpit Portlight
51	Foot block with lock off	Liegender Block mit Stopper
52	Foot block	Liegender Block
55	Steering pedestal with engine panel	Steuersäule m. Motorinstrumententafel
56	Waste water sucking point	Decksabsaugung Fäkalientank

## 1.2.3. Accommodation plan

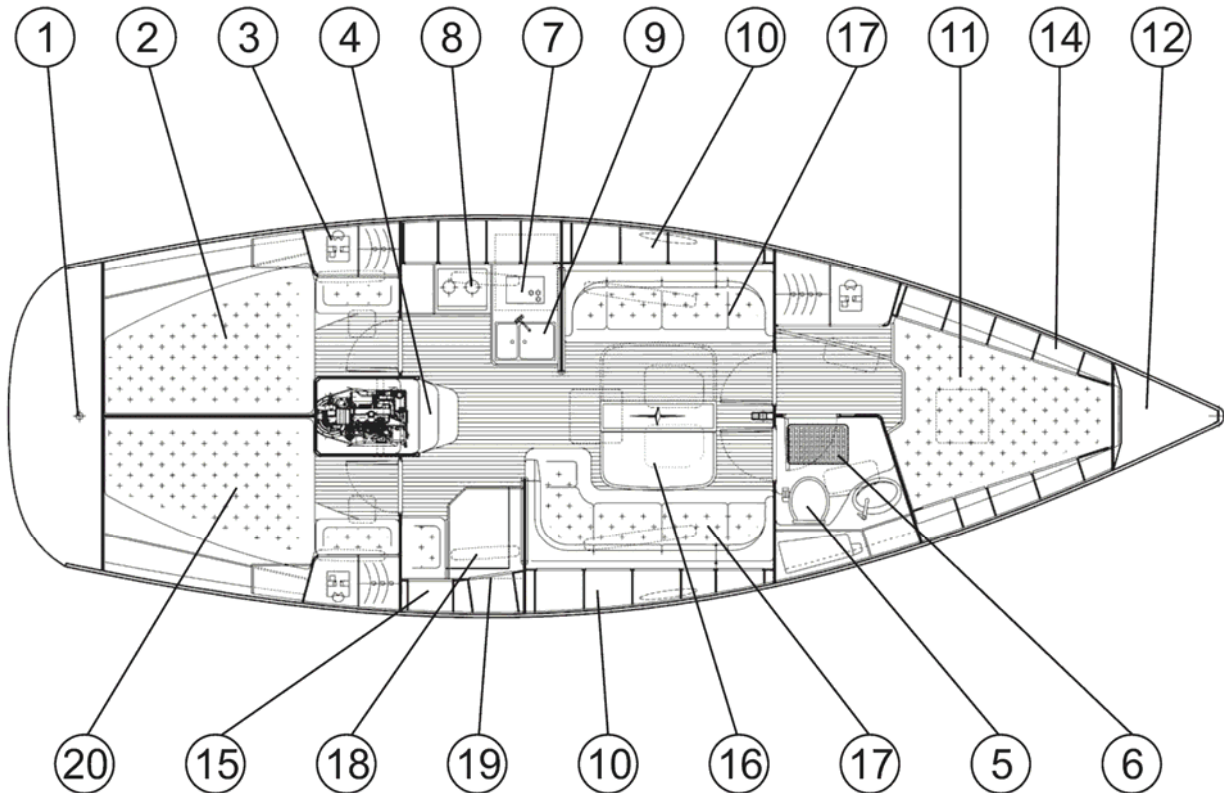

1	Steering gear	Ruderanlage
2	Double berth	Doppelbett
3	Shelf	Schrank
4	Companion way / engine room	Niedergang / Motorraum
5	Toilett	WC
6	Shower	Dusche
7	Cooling box	Kühlbox
8	Gas cooker with oven	Gasbackofen
9	Sink	Spüle
10	Hanging locker	Hängeschrank
11	Double berth	Doppelbett
12	Chain locker	Ankerkasten
14	Hanging locker	Hängeschrank
15	Book locker	Bücherschapp
16	Saloon table	Salontisch
17	Seating	Sitzgruppe
18	Chart table	Kartentisch
19	Electrical switch panel	Elektrische Schalttafel
20	Doubel berth	Doppelbett

### 1.3 Drive systems

#### 1.3.1 Sails

The SY Bavaria 38 Cruiser is equipped with the following standard sails:

Main sail - fully-battened	abt 33,10 sqm
Main sail - standard	abt 28,80 sqm
Furling Genoa (150 %)	abt 41,00 sqm

#### 1.3.2 Rigging

Mast length: LM- Profile, without taper; – 20 deg. double spreaders , angular; - 2 halyards, topping- and boom lifts, - Tipping line and fittings.

##### Boom

- LM-Profile; - clew outhaul; - 2 reefing lines; - eye for mainsheet; - eye for tipping line.

**Standing rigging** (made of 1x19–lace, material 4401), consisting of:

forestay with excessive footage (headsail reef system)	1x	intermediate shroud	2x
permanent backstay	1x	lower shroud	2x
permanent backstay tackle	1x	upper shroud	2x

##### Running Rigging

Inside the mast:

- Main halyard
- Genoa halyard
- Boom lift

Option:

- Spinnaker halyard (attached)
- Spinnaker uphaul
- Spinnaker downhaul

Inside the boom: 2 reefing lines (battened sail); 1 clew outhaul

*Additionally we refer to the enclosed trim instructions of the manufacturer.*



##### Caution

Before of every sail:

- Test strings, cordage, lanyards and split pins.
- Safeguard the split pins through adhesive tape or bending.
- Transpose deformed or damaged bolts.

#### 1.3.3 Motorizing, engine room, gear, and propeller

This yacht is equipped with a inboard diesel engine with a sail-drive gear and a fixed propeller. The engine room is separated from living quarters by plywood-bulkheads covered with sound-insulating material. An access is possible through:

- a shutter below the companion way,
- detachable bulkhead in the aft cabin beside the engine room
- revision opening in the toilet area for the oil filter

Cooling-water supply to the engine is realised via the saildrive-gear.

Engine plant

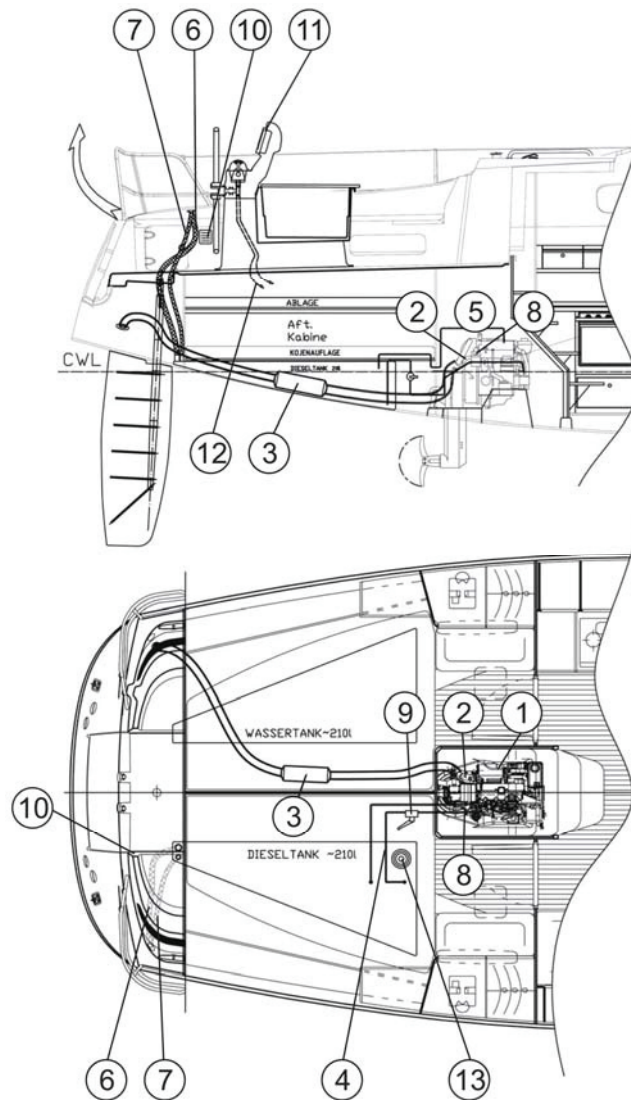

1	Engine Volvo	Motor Volvo
2	Engine exhaust system	Motorauspuffsystem
3	Exhaust water lock	Abgaswassersammler
4	Engine fuel intake	Kraftstoffzulauf
5	Feed back fuel	Kraftstoffrückführung
6	Fuel tank filling hose	Kraftstoffeinfüllstutzen
7	Fuel tank ventilator	Tankentlüftung
8	Fuel filter	Kraftstofffilter
9	Fuel cock	Kraftstoffabsperrhahn
10	Ventilator screens	Belüftungsroste
11	Engine panel	Motorinstrumententafel
12	Engine control cables	Motor-Fernbedienungskabel
13	Fuel gauge	Vorratgeber für Kraftstofftank

## 2. Installations and circuits

### 2.1 Tanks and piping - water

#### 2.1.1 Fresh water, drinking water –cold

The yacht has a water tank in the aft with a capacity of abt. 210 l. Fresh water is supplied via a water inlet at the transom, port side. You can take water from the tank over a hose connection leading to the pressure water-pump.

This pump, establishing the complete cold water circulation, is fitted port aft. An interruption of the operation of the pressure pump is done by cutting off all ducts. All pipes/hoses should be checked for leaks if the pump continuous working though all ducts were cut off properly. The pump is protected by a filter which should be regularly checked and cleaned if necessary. The filter is directly at the pump.

#### Components:

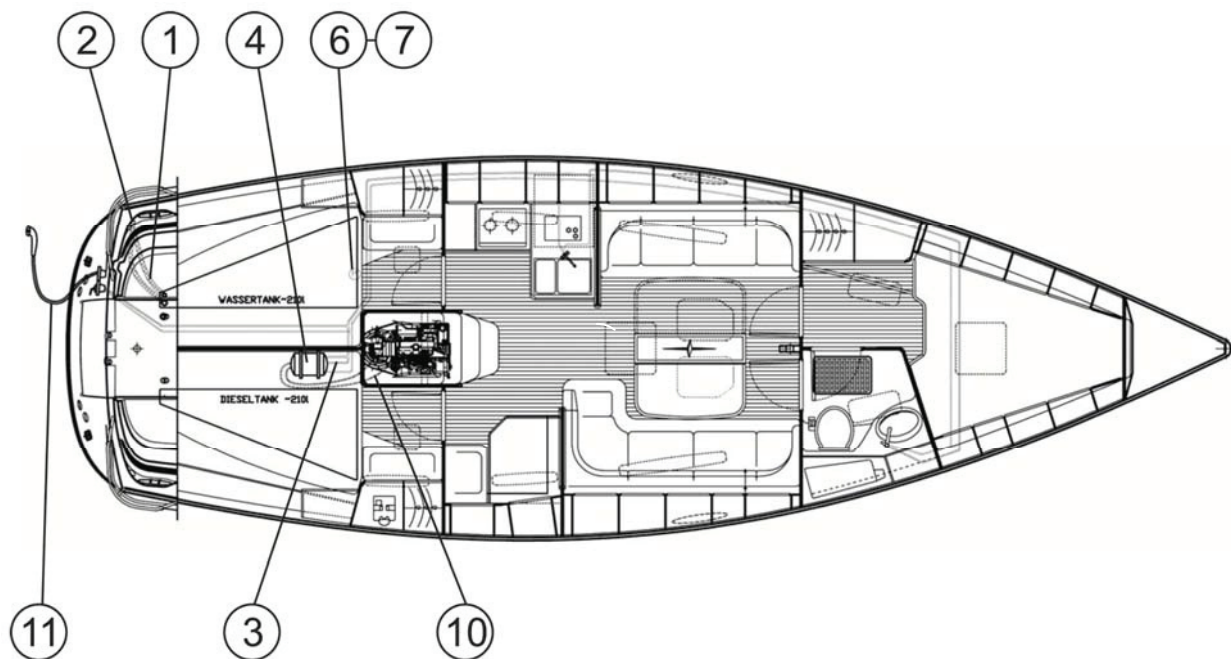

1	Tank venting	Tankentlüftung
2	Deck plate (inlet)	Einfüllstutzen
3	Return water heater	Rücklauf Boiler
4	Water heater	Boiler
6	Fresh water pump	Frischwasserpumpe
7	Accumulator tank and pressure switch	Druckgefäss und Druckschalter
10	Engine circular	Motorkreislauf
11	Shower	Cockpitdusche



#### Note

Exchange the water in tank from time to time. Additionally you should use common purifiers.

#### 2.1.2 Sea-water circulation

Sea-water is necessary for both WC flushing and engine cooling (see: 2.9).

## 2.1.3 WC –installation: see enclosed directions for use

**Attention**

If you are not aboard you should close all sea-valves.

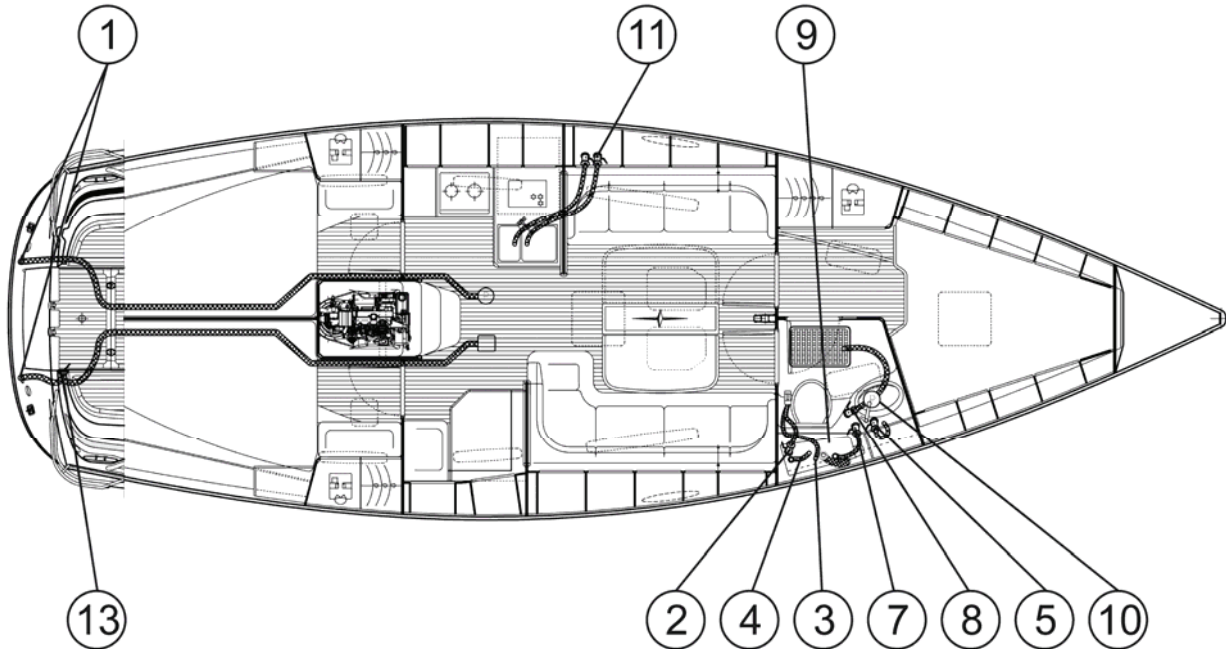
**Components: WC-flushing**

1	Outlet	Borrdurchlass
2	Toilet water drain valve	Kugelhahn Eingang WC
3	Toilet drain	Ausgang WC
4	Waste water tank venting	Fäkalientankentlüftung
5	Basin drain valve	Kugelhahn Ausgang Waschbecken
7	Waste water drain valve	Kugelhahn Ausgang Fäkalientank
8	El. shower drain pump valve	Kugelhahn Ausgang El. Duschpumpe
9	Waste water tank	Fäkalientank
10	Shower drain pump	el. Duschpumpe
11	Sink drain valve	Kugelhahn Ausgang Spüle
13	Manual operated bilge pump	Handlenzpumpe

## 2.2 Tanks and piping - fuel

### Storage tank

There is a 150 l plastic diesel tank with an inspection opening on starboard-side below the aft berths. It is filled via a fuel inlet with a red cover (marked with FUEL) at the transom of the yacht. The tank pickup is situated on the tank. The supply is made of a fire-proof fuel hose according to ISO 7840. The vent line is led to above deck.

### Supply of the engine

The engine is supplied via a suction pipe from the upper edge of the tank. Due to the short distance a fire proof fuel pipe is used. This is led via a wide-meshed filter/ water separator, fuel pump and fine filter to the engine and then back to the tank.



#### Attention

- A trouble free operation of the engine and heating is only possible, if the fuel is clean. That's why a regular inspection and cleaning of filter/water separator is unavoidable.
- The fuel tank should be completely emptied and cleaned once a year.



#### Warning

When refilling the tank:

- Switch off the engine, heating and stove!
- Do not smoke or use open lights!

## 2.3 Steering gear

### 2.3.1 Description of the system

The rudder is a suspended, balanced hydrofoil mid ship rudder. It is operated by hand from the steering wheels at the steering posts in the cockpit. Transmission of power is realised by means of chain control to the rudder quadrant. With the autopilot (option) there is an electric motor installed.

### 2.3.2 Rudder blade and rudder bearings

The rudder blade is a profiled one. It consists of a FRP-body. The rudder post is made of a sea-water resistant stainless steel (V4A) and is laminated into the blade. The post runs in two easy-going and special rudder bearings. The rudder is fixed by a mounting clip at the upper end of the post that also serves for the keeping of the rudder tiller.

The mounting clip is additionally secured with a straight stud bolt on the rudder post.



#### Attention

Check regularly and repair if necessary tight hold of the mounting clip on the rudder post.

The rudder bearings used by **BAVARIA YACHTBAU** are self-setting bearings. Since rudder bearings are subject to wear and tear they should be inspected and maintained regularly.

### Emergency tiller

The emergency tiller is stored in the starboard locker seat.

In case of emergency remove the steering wheel, the rudder quadrant for rope pulls and the quadrant for the auto pilot (option). The emergency tiller is to be mounted and secured at the top of the tiller wheel.



#### Attention

Remove the steering wheel in case of use the emergency tiller



#### Attention

Please ensure a suitable bearing lubrication of the necessary parts of the rudder installation with water-proof lubricants (or Teflon).

Bearing clearance has to be avoided and can be adjusted at the top bearing.

The post must have no clearance but should not need heavy movements.

The steering wheel got a built-in brake, which you can fasten. Make always sure that this brake is not tight especially when sailing with the auto pilot. This would mean an overload for the electric motor.

The socket of the steering gear is integrated into the deck's form. On the socket there is the casing of the wheel hub. A chain is laid over a tooth-wheel of the hub. Both the rope pulls are run from the rudder quadrant via fairleads to the ends of this chain, where they are fixed crosswise by means of wire-rope grips, protected with an elastic covering.

Each end of the rope pulls has one shroud adjuster each fixed at the rudder quadrant. It is recommendable to check these ropes from time to time and to retighten if necessary.

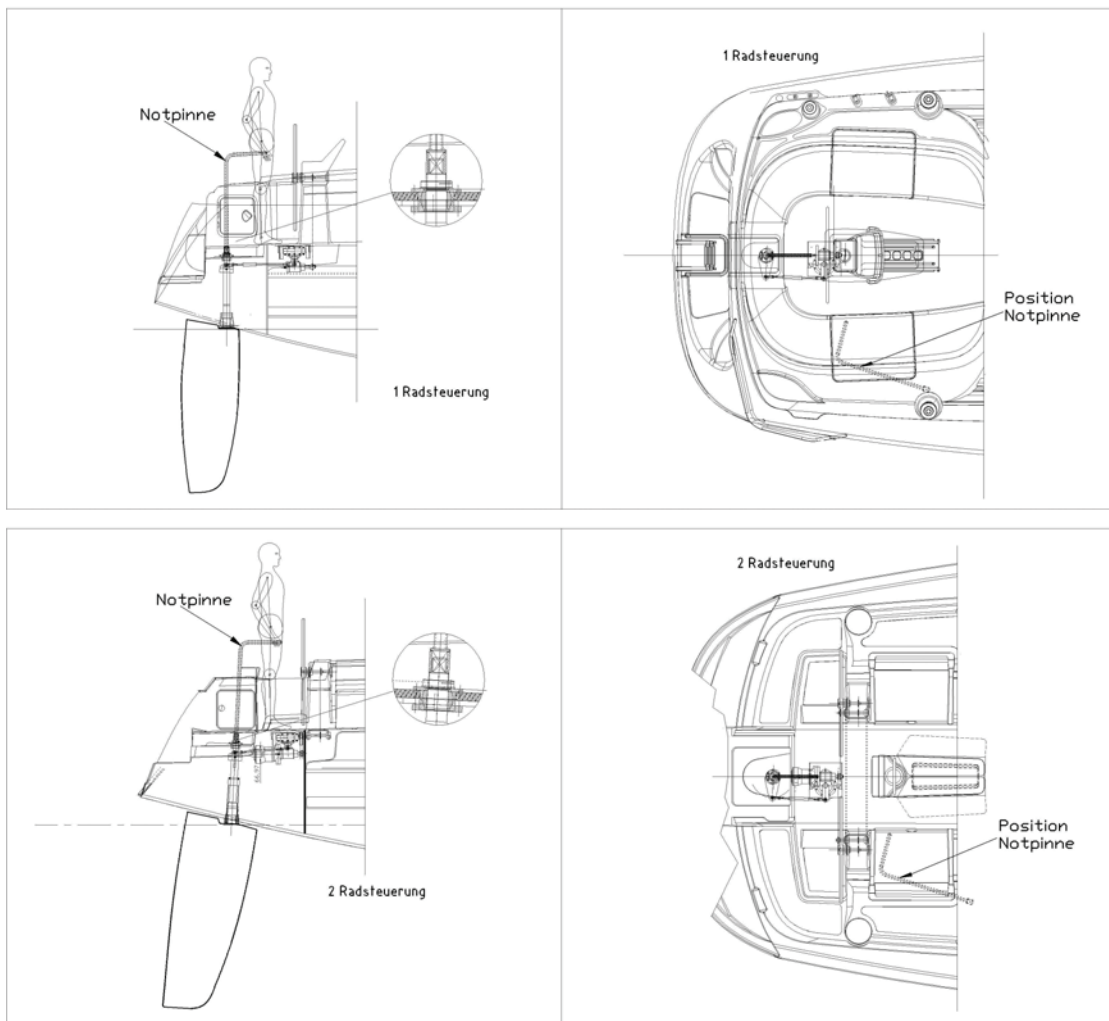

## 2.4. Bilge pumps, bilge pipes

The chain locker is made watertight towards the yacht. It is self-bailing through two holes in the skin. Bilge openings are to be cleaned regularly.

All BAVARIA yachts have got a self-bailing cockpit. The drain wells are placed at the rear and lowest part of the cockpit and are led outboard through the transom with hoses.

### 2.4.1 Description of the pumping arrangement

At BAVARIA Yachts the cockpit is self bailing. The moreover one the possibility of bailing water consists of the inside of the yacht. Both strainers are in the Bilge in the deepest place in the fair range. The soil bulkheads in the fair are connected by drillings, so that with possible water break-down both pumps can be used. The bail lines are shifted by means of hose after aft to the mirror (withdrawal). The cockpit bailing is made by the passage at the mirror (under the attendant seat).

In the anchor box are on both sides bilge openings, which are covered with a screen. In addition your yacht is equipped with a hand spring pump as well as an electrical bilge pump (achievement 75 l/min.).

With employment of the hand spring pump the pumping lever of the pump is to be pulled out. The spring procedure is made by pumping movements.

The electrical bilge pump is started by manipulation of the symbolically marked switch at the panel. - before in any case also main switch turns on –

We recommend to use the electrical bilge pump only with working machine; the full achievement of the electrical bilge pump will be reached then.

**A draw bucket is an ideal means for bailing out water. It should always be ready in a cockpit seat locker.**



#### Warning

In a serious situation, e.g. in case of a heavy inrush of water as a consequence of a collision, the pumping capacity might not be sufficient. Take measures for damage control with collision mats or other suitable means.



#### Attention

Close all sea valves if you leave your yacht. Valves being not clearly visible, like e.g. in the toilet room, should only be opened before use and closed short after.



#### Note

In case of spherical valves a transverse lever-direction indicates: CLOSED  
And a longitudinal ones means: OPEN

#### Maintenance note

The tightness of ducts should be inspected regularly.  
Retighten all hose clips and the stuffing boxes of valves

## Leakage-pot

For the case of a damage of a seacock or an on-board passage we recommend to carry on the yacht leakage potting from soft wood, whose diameter is co-ordinated with the different sizes of the on-board passages and can with those each opening be locked surely

Components of the bilge pumping installation: See pic 2.1.1.

## 2.5 The electric installation

### 2.5.1 The AC-installation 220 Volt

The yacht has got a shore connection (option) by which it can be supplied with electric power from ashore when being berthed in a port. The plug box (meeting the CEE-norm) is installed at the starboard locker seat of the yacht. The power is supplied into a shore connection unit, placed under the chart table.

### 2.5.2 The DC-board net 12 Volt

All electric devices aboard are supplied with the 12 V DC. A main-switch is installed in the electric panel under the chart table. Power distribution is effected by a switchboard above the chart table. The lettering next to each switch refers to the corresponding consumer-group.

You can find all the switches for the 12 V consumers at the switchboard. By this you can operate different consumer-groups, being marked with logos or lettering, separately. Some of the switches are designed for an installation of additional electric devices. The motor vehicle flatconnectors are arranged on the back of the panel.

### 2.5.3 Operating the installation and specific features

The combination of an AC- with a DC installation offers a clearly higher comfort but requires some special knowledge.



- Make sure that your standardized CEE plug is compatible with the phases of the land plug socket.
- Control and renew regularly the wear condition of the underwater anode of the potential equalization.

### Charging the batteries

All batteries are maintenance-poor and drain-protected. They are charged via a buffer diode by the motor-generator. Charging the starter battery always takes priority to ensure a safe start of the engine.

### AC-consumers

The safety contact plug-box at the electric panel is designed for electric tools to be used for small repair work. Further plug sockets are in the toilet areas, the pantry and at the water heater.

### DC-consumers

The essential consumers are:

- |                             |                     |
|-----------------------------|---------------------|
| - navigation lights         | -bilge pumps        |
| - engine displays           | -tank display       |
| - VHF-radio wiring (option) | -electronic devices |
| - devices for comfort       |                     |

Navigation lights have absolute priority. In case of a lack of capacity all other consumers have to be switched off first. By a stand-by operation of the engine, even when under sail, the batteries can be brought up rather quickly. After a while you can switch on the other consumers again.

### 2.5.4 Important warnings on the DC-installation (12 Volt)



#### Never

- a) work on electric installation while the system is energized
- b) modify the craft's electrical system or relevant drawings: installation, alterations and maintenance should be performed by a competent marine electrical technician.
- c) alter or modify the rated current amperage of overcurrent protective devices;
- d) install or replace electrical appliances or devices with components exceeding the rated current amperage of the circuit;
- e) leave the craft unattended with the electrical system energized, except automatic bilge-pump, fire protection and alarm circuits.

### 2.5.5 Important warnings on the AC-installation (230 Volt/115 Volt)



- a) Never work on electric installation while the system is energized
- b) Do not modify the craft's electrical systems or relevant drawings. Installation, alterations and maintenance should be performed by a competent marine electrical technician. Inspect the system at least biennially.
- c) Disconnect shore-power connections when the system is not in use and while working at the electrical system.
- d) Connect metallic housings or enclosures of installed electrical appliances to the protective conductor system in the craft (green or green with a yellow stripe conductor).
- e) Use double insulated or grounded (earthed) electrical appliances.
- f) **WARNING:** Do not allow the shore-power cable end to hang in the water. An electrical field can be caused which can cause injury or death to nearby swimmers.
- g) **WARNING:** To minimize shock and fire hazards:
  - Turn off craft's shore-power connection switch before connecting or disconnecting shore-power cable.
  - Connect shore-power cable to craft's inlet before connecting to shore-power source.
  - Close shore-power inlet cover tightly.
  - Do not alter shore-power cable connectors, use only compatible connectors.

2.5.6 Distribution of electric devices:

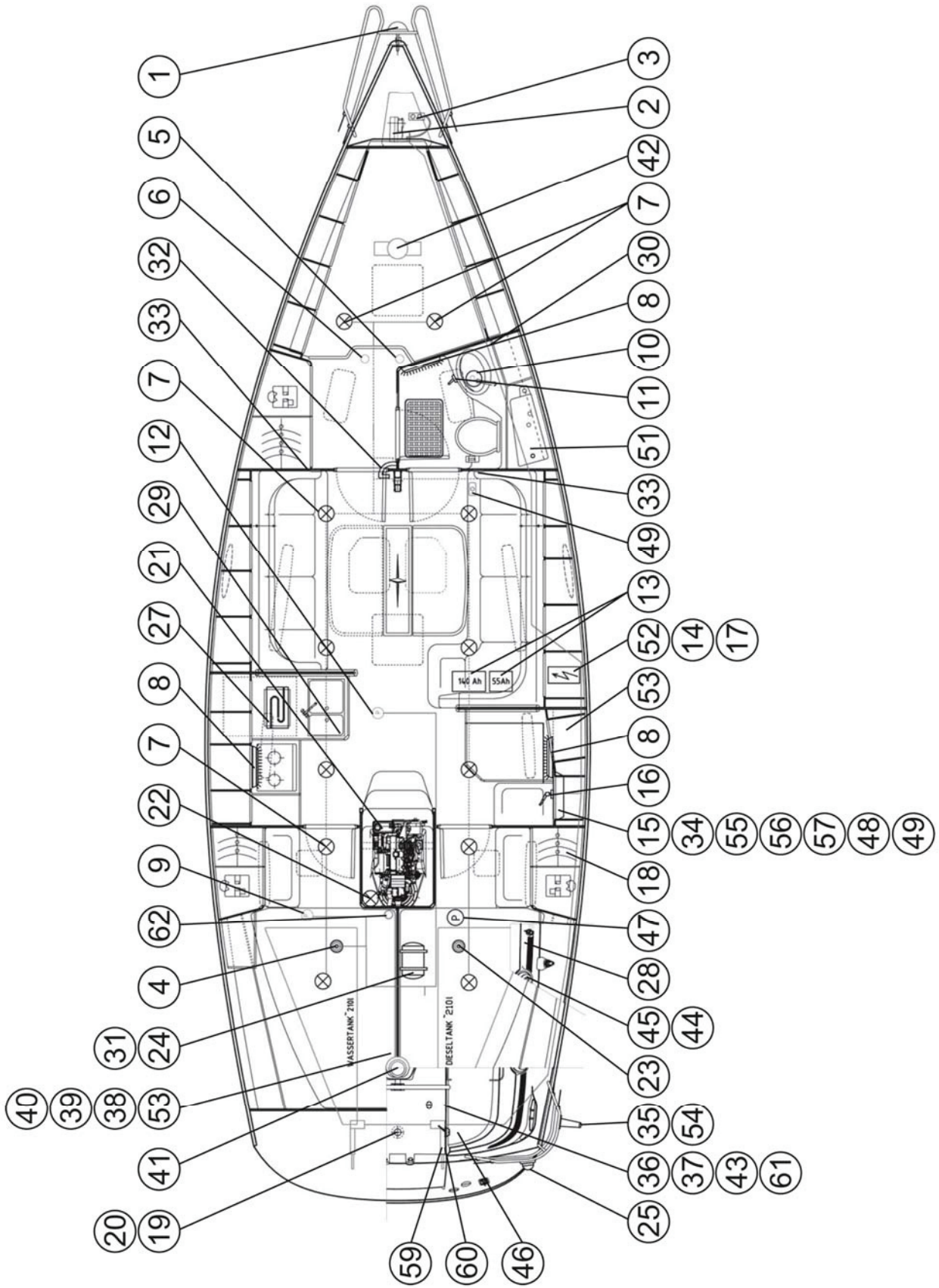

1	Navigational light	Zweifartenleuchte
2	Electric windlass	Elektrische Ankerwinde
3	Windlass switch	Bedienteil Ankerwinde
4	Fresh water gauge	Frischwassertankgeber
5	Echo sounder	Echolot Geber
6	Log	Sumlog Geber
7	Light	Halogenleuchten
8	Neon lamp	Neonleuchten
9	Water pump	Wasserpumpe
10	Shower drain pump	Duschpumpe
11	Shower drain switch	Duschschalter
12	Bilge pump	Elektrische Lenzpumpe
13	Batteries	Batterien
14	Battery charger	Batterie Ladegerät
15	Electric panel	Elektro Panel
16	Main switch (engine/consumer)	Hauptschalter (Motor/Verbraucher)
17	Auto pilot – option	Kurscomputer Auto - Optional
18	Compass – option	Kompass Auto - Optional
19	Repeater – option	Rückholgeber Auto - Optional
20	Auto engine – option	Motor Auto - Optional
21	Engine start	Anlasser Motor
22	Battery isolator	Batterie Trenndiode
23	Fuel tank gauge	Dieseltankgeber
24	Water heater	Boiler
25	Stern light	Heckleuchte
26	Refrigerator	Kühlschrank
27	Cooling unit	Kühlaggregat
28	Shore socket 230 V	Landanschluss 230 V
29	Socket 230 V	Steckdose Küche 230 V
30	Socket 230 V	Steckdose Duschaum 230 V
31	Socket 230 V	Steckdose Boiler
32	Cable penetration	Kabeldurchführung
33	Speaker -option	Lautsprecher - Optional
34	Radio – option	Radio - Optional
35	Radio antenna - option	Antennenkabel Radio – Optional
36	Engine panel	Motor Panel
37	Tank gauge	Tankuhr
38	Tridata unit	Tridata Bedienteil
39	Wind gauge	Wind Bedienteil
40	Autopilot unit – option	Autopilot Bedienteil – Optional
41	Compass	Kompass
42	Bow thrusters engine – option	Bugstrahlruder motor – Optional
43	Bow thrusters unit – option	Steuerung Bugstrahlruder – Optional
44	Genua winsh unit – option	Genuawinsch Bedienteil – Optional
45	Genua winsh motor – option	Genuawinschen Motor – Optional
46	Heater – option	Heizung – Optional
47	Heater fuel pump – option	Dieselpumpe Heizung – Optional
48	Heater thermostat – option	Thermostat Heizung – Optional
49	Heater gauge – option	Fühler Heizung – optional
50	Generator - option	Generator- optional
51	Waste water tank gauge	Fäkalientankgeber
52	Fuse	Sicherung
53	Map plotter	Kartenplotter
54	GPS antenna	GPS Antenne
55	Relay autopilot	Relais Autopilot
56	Fuse battery charger	Sicherung Ladegerät
57	Relay anchor winch	Ankerspillrelais
59	Bathing Platform	Dinghi Lifter Badeplattform
60	Bathing Platform drivebox	Steuerungskasten Dinghilifter
61	Bathing platform switch	Taster Heckklappe
62	Earth	Erdung

### 2.5.7 Wiring plans

### 2.5.8 Distribution plans

### 2.5.9 AC-Distribution

See provided e-documentation

### 2.6 L.P.G. installation

The gas installation for the stove meets the European norm EN 10239. The test-certificate is attached.

The gas pipe leading to the stove from the standard 3 kg-gas cylinder is an 8 mm copper pipe. It is placed into a self-bailing casing moulded into the deck in the rear cockpit area. All gas pipes have been installed according to the German safety regulations. The best-by date for the soft connection hoses between the gas cylinder and the copper pipe and between copper pipe and stove is printed onto the hoses. They have to be replaced after the expiry date.

The reducing valve in the gas cylinder casing has a service pressure of 30 mbar. The flow rate is 1 kg/h.

#### 2.6.1 The components

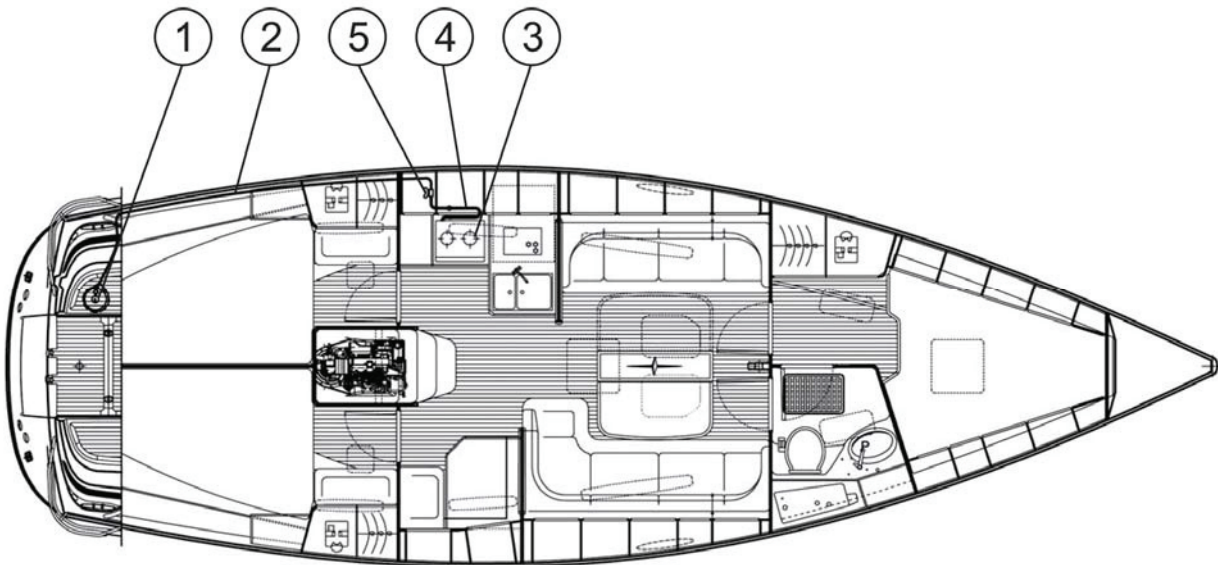

1	Gas tank with valve	Gasflasche mit Reduzierventil
2	Copper tube	Kupferrohr
3	Gas stove with oven	Gaskocher mit Backofen
4	Rubber hose	Gummischlauch
5	Gas stop valve	Gaskugelhahn

### 2.6.2 Operation

Gas installations require care. That's why you should follow this sequence:



**Attention**

- Open the stop valve in the gas cylinder casing
- Open the valve before the stove
- Open a stove valve and lighten the gas
- Keep the valve open until the glow timer allows further burning.



**Attention**

- When switching off use the following sequence: First close valve in the bottle case and then the valve in the pantry.



**Attention:**

- Do not use liquids containing ammonia for checking the pipe.
- Never handle with open light when looking for a leakage
- Do not smoke or when connecting a new gas cylinder.

**And here is some more advice on how to prevent difficulties with the gas installation:**

- Close all gas valves if the stove is not in use. In a case of emergency you should close the valves immediately.
- The stove valves have to be closed before the gas cylinder valve is opened.
- Check the L.P.G. installation for possible leakages regularly. Check all connections with soap suds or the like (for doing so the stove valves have to be closed – all other valves of the installation have to be open).
- If you find any leakages close all valves and have the installation repaired by a specialist before further use.
- Since the flames consume oxygen a proper airing and de-aeration is necessary. Do not use the stove for heating the cabin.
- Valves of empty gas cylinders have to be closed and disconnected from the installation. Have the covers ready.
- Do not use the gas cylinder casing for storing other equipment.
- Never leave your yacht unattended if the stove is in use.
- Check the hose pipes at least once a year. Let these replace periodically.
- If you install a new stove make sure that it has got the same working pressure.
- Check the elements at least once a year. Let these periodically replace.



Open exhausts and hatches while using the stove.  
The stove may not be used as heating.

### 2.7 Fire protection

When building the yacht special attention was paid to avoid the risks of fire. This includes the choice of materials, the distance of stove flames to the surrounding built-in furniture and an island position of the engine. The engine room has got a lining with fire resistant insulating material.

As the owner of the yacht you should keep this state and pay attention to the following advice:



**Attention:**

- Keep the bilge clean and check regularly if there is a smell of fuels or gas.
- Do not have any freely suspended curtains above or close to the stove or other devices with open fire.
- Inflammable material must not be stored in the engine room. If you store non-inflammable materials in the engine room make sure that they are protected against falling into the engine installation or are in the way.
- Follow the national equipment requirements for fire-fighting equipment.

Furthermore you and your crew can support fire protection if you follow the following advice:



**Never**

- obstruct any exits or hatches.
- alter safety installations like fuel- and gas valves and electric switches and the like.
- change something at the vehicles (above all not at electrical, fuel or gas-installations).
- leave the yacht unattended if the stove or the heating is in use.

**Never**

- use gas lights in the yacht.
- fuel the tank or replace gas cylinders if the engine is running or if the stove or heating is used.
- smoke or use open lights while handling with fuel or gas.

The well-known sources of danger on board are the stove in the pantry and the engine room. If, despite all precautionary measures, a fire should break out aboard, there are three fire extinguishers a board which are fixed at the following places:

Nr. 1+2: **Powder extinguisher** in the starboard locker seat, at least fire grade 10A/68B

Nr. 3: **Powder extinguisher** in the navigational seat, at least fire grade 10A/68B

Additionally a light **fire retarding cloth** is placed in the pantry, which is made of glass cloth and is very useful in the case of fire caused by overheat fat.

**It is the yacht owners duty**

- to have all fire extinguishers regularly checked and maintained ;
- to have fire extinguishers replaced after the expiry date. The same goes if the extinguishers should have been used. The new extinguishers should at least have the same capacity as the discussed ones.

**It is the yacht owners or skippers duty**

To make sure that

- all extinguishers are freely accessible
- to inform all persons on board about:
  - the position and use of all fire extinguishers and the fire retarding cloth,
  - the position and function of the opening for the extinguishers nozzle in the engine room bulkhead,
  - the exit through the escape hatch above the fore-berths.



**Caution**

Test the fire extinguishers regularly!  
Train yourself as regards fire fighting.  
**Always obey seaman's duty!**

## 2.8 Anchor-, towing- and warping facilities

The bower anchor (plough anchor), about 15 kg, hot-galvanised, (is known for its high holding power). It lays ready-to-fall in the bow fitting. The chain has a length of 50 m and a nominal thickness of 8 mm. It is run out by an electric anchor windlass operated with a remote control. The remote control is placed in the chain locker before use and its function is activated at the switch board.

You should always be a claw or an anchor chain hoist used to anchor the winch to relieve. This is then placed on the cleat.

Furthermore it is recommendable to have a stern anchor (possibly swivel armature) as well as sufficient mooring- and towing lines with the necessary strength on board:

1 stern folding anchor (4-fluke grapnel anchor), 12 kg, hot-galvanised, fixed at the aft guard-rail. 6 m chain forerunner, thickness 7 mm, 34 m polyamide anchor rope, 18 mm, 3-strand hawser laid. It is stored in the port transom seat.

The rope is cleated aft.



### Warning!

Always tow or be towed at a slow speed. Never exceed the hull speed of a displacement craft when being towed.



### Warning!

A tow line shall always be made fast in such a way that it can be released when under load.



### Warning!

It is the owner's/operators responsibility to ensure that mooring lines, towing lines, anchor chain(s), anchor lines and anchor(s) are adequate for the vessel's intended use, i.e. the lines or chains do not exceed 80 % of the breaking strength of the respective strong point.

Owners should also consider what action will be necessary when securing a tow line on board.

## 2.9 Engine cooling system

### Engine cooling

The engine has got a two-circuit cooling system. Water enters through the saildrive, is led to the heat exchanger and then injected into the exhaust gas pipe. Together with the exhaust gas the cooling sea water is exhausted via the silencer and the exhaust pipe at the stern. This guarantees a trouble-free engine operation. Moreover the engine noise is reduced.

All hose connections of the system are secured with double stainless steel clips.



### Attention

- Check and clean the sea water filter in regular intervals, depending on the water quality.
- Before starting the engine, make sure that the cooling water inlet is open.
- Have a short look into the engine room for possible leakage.
- When the engine is running it is highly recommendable to check regularly if cooling water is escaping with the exhaust gas.
- If the sea-cooling water cycle precipitates, the optical and acoustic warning responds. Turn in this case engine off immediately and check the cooling system.

### 2.10 Exhaust gas system

The yacht is fitted with a "wet" exhaust gas system, i.e. cooling sea water is injected into the exhaust gas elbow causing a cooling of exhaust gases. This mixture is led down into a silencer/water lock, runs through a pipe in the locker seat on the starboard side of the aft cabin, is led upwards at the stern and escapes to the side above the water-line.

The exhaust gas hose consists of a synthetic rubber material with an integrated steel spiral.

The hose is heat-resistant (for some time) and should be checked and replaced if necessary.

A constant flow of sea water has to be guaranteed. The hose is secured at its joints with two clips.

If there is an interruption of the sea water flow, the temperature sensor in the exhaust gas hose will release a visual and acoustic warning. In this event you should stop and switch off the engine immediately until the problem has been settled (see manual of the engine manufacturer).



#### Attention

A regular Inspection if saltwater comes out of the exhaust is urgently advisable.

### 2.11 Ventilation/Airing

We have taken the following measures for a proper ventilation of all rooms:

#### Chain locker

Certain ventilation is achieved through the hawser port in the cover of the chain locker and through its bilge holes.

#### Living cabins/ Salon

2 escape hatches, 4 side lights, 2 bull's eyes, 2 deck ventilator

#### Aft cabin (starboard)

1 escape hatch, 1 side light to the cockpit

#### Aft cabin (portside)

1 escape hatch, 1 side light window to the cockpit

#### Toiletroom

1 escape hatch (3 cabin-version), 1 escape hatch , 1 side light (2 cabin-version)

### 2.12 Board ducts, sea water valves

Openings below the water line are possible weak spots. That is why we pay special attention to them.

All board ducts in the underwater part, with the exception of the duct for the transmitter of the echo sounder, consist of brass-made screwed joints with spherical sea valves and hose nipples. All hose connections are secured with two clips each.



#### Attention

Close all sea valves if you leave the yacht. Valves being not clearly visible, like e.g. in the toilet room, should only be opened for use.



#### Maintenance note

The tightness of board ducts should be inspected regularly.  
Check and retighten all hose clips and stuffing boxes of valves if necessary.



#### Note

In case of spherical valves a transverse lever-direction indicates : CLOSED  
And a longitudinal direction means: OPEN.

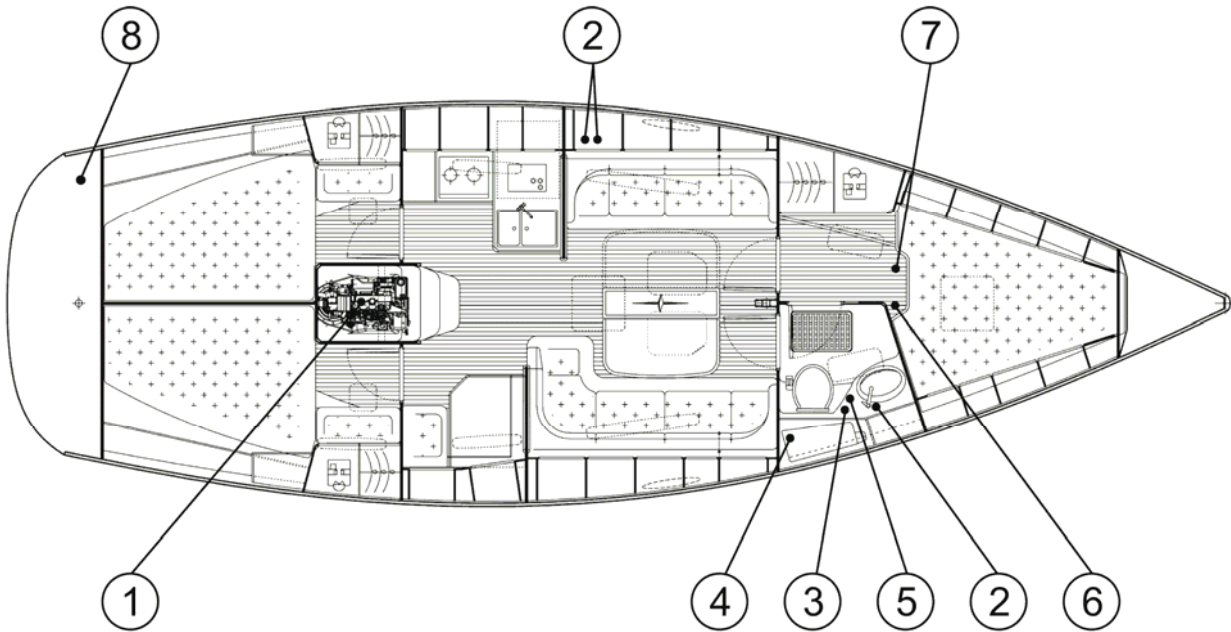
**Board ducts:**

1	Cooling water strainer/ Water inlet	Kühlwasserfilter/ Kühlwassereinlass
2	Sink drain	Ausgang Spüle
3	Waste water drain	Ausgang Fäkalientank
4	Toilet water inlet	Eingang WC
5	Shower drain pump	Ausgang Duschpumpe
6	Echo sounder	Echolot
7	Log	Geschwindigkeitsmesser
8	Exhaust drain	Ausgang Auspuff

**2.13 Generator (Option für 44vision, 50vision, 50 Cruiser, 51 Cruiser)****Attention**

For maintenance and care on a regularly basis of e.g. oil level, filter, etc. see manual.

### **3. Environmental protection**

**BAVARIA YACHTBAU** has already met the legal requirements referring to exhaust gas regulations with its choice for the inboard diesel installed. An exhaust gas type-examination certificate can be handed in or sent on later.

#### **3.1 Fuel and oil**

You should be especially careful when filling the tank. A (wet) cloth around the fuel inlet can prevent fuel from dripping into water. In your engine manual you can also find a diagram with a curve about the specific fuel consumption thus offering you some good hint on the most favourable engine speed.

For a necessary exchange of oil you should use a suction pump, because you cannot drain it off like a car. The oil has to be exchanged at least once a year, even in case of a little operation time of the engine.

A well-maintained engine should never leak. But in order to prevent even smallest amounts of oil being discharged overboard with the pumped out bilge water, the engine bed has been designed in form of a closed oil sump. All water from this sump, being possibly mixed with oil, has to be pumped into a separate canister and has to be deposited ashore.

In any case there should be oil-binders aboard.

#### **3.2 Waste**

For all water sportsmen it goes without saying: waste is not thrown overboard. This is also true for biodegradable waste. There should be a regular waste bag or -bin in a locker seat.

#### **3.3 Sound**

The wet exhaust pipe of the diesel engine reduces the engine sound considerably. Additionally rubber bearings, elastic couplings and the engine room insulation minimise sound emissions. Nevertheless you should not turn up the engine too quickly and, please, reduce the engine speed in waters with dense traffic.

#### **3.4 Swell**

Natural bank areas are sensitive against swell. Please keep sufficient berth. Formation of waves, caused by your yacht, is an indicator of where and when you should reduce your speed to avoid unnecessary swell. Pay attention to relevant signs.

#### **3.5 Exhaust gas**

Check the escaping exhaust gas regularly. The exhaust gas should show neither black smoke nor blue clouds. In such a case you should either clean the air filter or have a repair shop readjusted the engine.

#### **3.6 Antifouling coatings**

The underwater part of the hull of each yacht has to be protected with an antifouling coating because marine growth means more energy for propulsion. Today there is a wide range of protective paint with various effects for different bodies of water. Trust the recommendations of specialists for your decision. Coatings that are effective for years without any grinding in between are especially recommendable.

But if the coating has to be sanded to some extent you should arrange these activities with the port officials. Generally the ground under the yacht has to be covered with some plastic cloth to collect the rubbed down dust and dispose it.

#### **3.7 Varnish removers**

Most varnish removers contain aggressive substances and should not be used or as little as possible. A mechanical removal of paint is the much better way.

## 4. Maintenance

### 4.1 Maintenance, cleaning

#### 1. Mast and rigging

See: Notes of the manufacturer

#### Sails

The sails are made of Dacron. This material is very robust and resistant. Thus the sails keep their form for a very long time.

Inspect all your running and standing rigging carefully for sharp edges, splints, protruding ends of wire and the like because laminated cloth is especially sensitive against touching them. Those parts of the cloth that can chafe at spreaders or shrouds should be protected on both sides by sticking self-adhesive cloth to them. The same goes for the foot of the sail if there is the possibility of chafing at the rails.



#### Note:

- Please remember: Damage to the cloth is mainly caused if it is incorrectly treated or handled. Especially if you let it shake, expose it to UV rays constantly or store it improperly.
- If there are any questions on the cloths do not hesitate to contact the manufacturer or your sail maker.
- Never remove track cars with ball bearings from the tracks carelessly. Always use sheet tracks with end stops.

#### Cleaning

Please clean your yacht immediately after you have taken it out of the water. High pressure cleaning devices will remove any growth. This is followed by an up keeping of the surface of the yacht. All paint manufacturers provide detailed instructions for their coating systems.

For ships sailing in salt waters: remains of salt absorb water and can cause a faster corrosion. Where- and whenever it is possible you should rinse the yacht and parts of it with fresh water.

#### Care and maintenance of teak decks

Untreated teak weathers to a natural silver-grey colour, with no detriment to the timber's strength or other mechanical/physical properties. Because of teak's inherent durability and weather-resistant properties, the use of protective paints or coatings is neither necessary nor advisable.

Practical tips on care and maintenance:

*Protective wood care oils* – penetrate deep into the timber, and under the influence of heat and moisture can adversely affect the adhesion of the caulking material to the sides of the joint. As a result, the seal between the caulking material and the sides of the joint may break down, allowing water to enter.

*Paints and lacquers* are decorative coatings which, when applied to a teak deck, dry to form a continuous film over the caulking material as well. Some paints will not dry properly where they come into contact with the caulking material, leaving the surface tacky. In time most paints will flake away along the line of the joint. This spoils the appearance of the teak deck and causes cracks to open up along the joints.

*Teak cleaners* should be used only if they contain no other active ingredients apart from normal soap. Additives such as phosphoric or oxalic acid, which are often incorporated as brighteners, are corrosive substances which attack both the caulking material and the timber, causing them to age rapidly.

We therefore recommend that teak decks be swabbed down with a mop and clean fresh water, to which a small quantity of normal soap may be added if desired. Heavy soiling may be removed by scrubbing with a hard sponge. The use of a power washer is not recommended. The *high-pressure water jet* will remove areas of sapwood and break the seal between the caulking material and the sides of the joint.

In extended periods of hot, dry weather teak decks should be watered at regular intervals to prevent the timber from drying out completely. Excessive loss of moisture will cause the timber to shrink, placing the joints under stress. Under unfavourable conditions this can lead to premature ageing or failure of the joint seal.

**Stainless steel**

The corrosion resistance of all fittings is based on their ability to constitute a thin skin together with the air oxidant, which makes a positive electrical potential. Specialists call it a CR-passive (CR is standing for chrome). But chrome is in the galvanic contact series negative and a bit less valuable than iron. If the thin protection skin is damaged the stainless CR will be active and less good than pure chrome. The corrosion can start.

Who is not disappointed about little brown spots on the fittings? They are caused by flying rust or particles of iron, which are in the air and in all harbours placed near big towns. As soon as the flying rust settles onto the protective coat of the stainless steel, it destroys the CR-passivity very aggressively and fast.

Stainless steel only stays good looking for a long time, if it is taken good care of it.

Make it your habit to also clean the rail stanchions, pulpits and push pits and all stainless fittings thoroughly too if you are washing your boat with clear water. Clear water will wash away the salt, rust and flying rust, the protective coat will be "ventilated" and its function is guaranteed again.

If you have already brown spots, you can use most of all available metal cleanings to take care of the stainless steel fittings or you take normal polish like you use it for the hull.

Of course – all the best care can not help, if in the first place the fittings are not made out of the right material or the stainless steel has not been treated correct. Before you will buy the fitting, ask for example if the fitting has been polished electrical.

**4.2 Wearing- and spare parts**

As an experienced skipper you will not have difficulties in getting original spare parts. If you need any help, please contact the yard.

If you need any spare parts but cannot get the original ones you have to pay attention to the stability values to keep the yacht at the high technical standard it used to have at the time of delivery.

**4.3 Repair work**

In need of repair of the hull you may consult a reliable workshop. The interior construction was designed in such a way that a non-destructive elimination of defects can be realised.

In regard to the technical equipment you may contact a reliable work shop or the shipyard, too.

**4.4 Winter storage**

We have already given some well-directed advice on winter storage in different paragraphs of this manual. Generally speaking all firms offering winter storage should meet the latest technological standard as far as environmental conditions, storage blocks, fire protection and accessibility of your yacht is concerned. Moreover there should be fixed rules for work, done by the owner himself, to prevent any interference with other sportsmen.

If possible the following objects should be taken from board and stored in a dry and frost-free place:

- Ship's papers and other relevant documents
- Charts, books and instruments
- Mattresses, upholstery, blankets and sleeping bags
- Sails and lines/ropes
- Foodstuffs
- Gas cylinders
- Safety equipment
- Life raft and rubber dinghy
- Batteries

#### **Advice:**

**Before wintering you should pay special attention to the following parts and protect them correspondingly:**

- Rinse and clean the transmitters of the speedometer and echo sounder.
- Maintain the electrical systems and clean them with suitable materials.
- Water pipes can be successfully cleaned with soft acids, e.g. white vinegar.
- Water valves should be taken to pieces and greased.
- The toilet and corresponding pipes are cleaned with fresh water.
- The rudder should be fixed that no movements are possible (e.g. by fixing the tiller or wheel).

#### **Engine:**

- Fill the fuel tank completely
- Exchange the propeller's sacrificial anode (if necessary).
- Empty all cooling-water of the engine and follow the instructions of the manufacturer.
- Slacken all belts (lighting engine and other engine driven devices).

#### **Winter storage**

- Observe all notes in the engine manual.
- Store the fully charged batteries at a ventilated frost-free place.
- Grease the steering wire and –components
- Remove all water out of the ship and protect it against rainwater entering it.
- Replace all components which seem not to be reliable any longer.

#### **Mast and rigging**

It may not always be possible, but it is recommendable:

- Unship the mast,
- Refit all standing and running rigging,
- Inspect the cables and other wires,
- Inspect bolts, spanners and other tie points for possible fatigue of material or cracks,
- Rinse all aluminium parts with fresh water
- Rinse all lines/ropes with fresh water and store them in a dry place,
- Rinse and grease all guide rollers of the mast and the boom.

## 5. Final remarks and notes

This manual is in conformity with the directives of the harmonised European Norm EN 10240. Much of it might go without saying for you. Nevertheless we hope that dealing with the different chapters of this manual will help you to understand the technical systems and the ideas behind them. As already mentioned in the introduction, the purpose of this manual is to contribute to an unspoilt use of the yacht.

Among the things that are not dealt with is e.g. the personal safety equipment. This solely belongs to the responsibilities of the skipper. It goes without saying that there have to be means of rescue for all persons on board. But this also includes the procurement and maintenance of a life raft, of signalling means, a first-aid-as well as a tool-kit.

Since the European Recreational Craft Directive pays special attention to fire protection it shall also be mentioned, that fire extinguishers have to be maintained in regular intervals and that it belongs to the duties of a skipper to introduce his crew into their operation.

Those being prepared for an emergency are normally never involved. But just in case: the yacht is properly equipped for those situations with suitable means.

We are constantly working on further developments of our sailing yachts. We hope you will understand that we have to reserve the right to carry out changes as far as form, equipment and technology is concerned. For these reasons you cannot lay claim to a complete correspondence of your yacht with the information, figures and descriptions in this manual.

If your yacht should be equipped with any details not being referred to in this manual or in the owner's file, your party to the contract will inform you about the correct operation and maintenance.

Since all yachts, manufactured by **BAVARIA Yachtbau GmbH**, are exclusively sold by official dealers there is no contractual relationship between the yard and the customer/owner.

Thus **BAVARIA Yachtbau GmbH** is not familiar with details of the contract between the dealer and the customer. That's why it is not urgently necessary that your party to the contract takes over the full extent of our warranty conditions.

So, if you have to make a claim it is unavoidable to contact your party to the contract.